

Type 1032 Fractional Sanitary Pressure Gauge

Actual material certificates and certificate of conformance supplied as standard to EN 10204:2004 3.1



SEE NOTE (1)



FEATURES

- All-welded 316L SS Bourdon tube
- Welded 316L SS diaphragm and seal housing
- USP grade glycerin (99.5% pure, system fill) standard
- 304 SS electropolished case and ring
- Electropolished diaphragm & housing
- Individual calibration certificates provided on request (XC4)
- Liquid-filled performance with dry gauges available with Flutterguard™⁽¹⁾ lubricated movement⁽²⁾

Ashcroft® Type 1032 fractional sanitary pressure gauges have specifically been designed to meet the needs of the pharmaceutical, bio-tech, filtration, food and dairy markets. With a quick-connect clamp and diaphragm surface finish that is electropolished to 12-20RA these instruments are also suitable for use in breweries, wineries and citrus juice production plants. With a small dial size and 3/4" Triclamp connection the 20-1032 is well suited for small scale pilot operations as well as space limited applications. The 20-1032 is only available as a dry gauge but with the Flutterguard™⁽¹⁾ lubricated movement option operators can have comparable protection without the issues or limitations associated with liquid-filled gauges.

(1) XZY Flutterguard design is not recommended for gauges expected to be exposed to temperatures over 200°F (93°C). This includes gauges subjected to autoclaving.

(2) Available on application. See PI page SA/PI-16 for more information.

SPECIFICATIONS

Dial Size: 2"

Accuracy: 3% upscale, up to 5% downscale

Case & Ring Material: 304 SS electropolished

Ring Type: Stainless steel, friction fit

Bourdon Tube and Socket Material: 316L SS

Diaphragm Material & Surface Finish: 316L SS, 12 to 20 RA electropolished

Process Connection: 3/4" Tri-Clamp only

Connection Location: Lower only

System Fill: USP food grade glycerin standard. Other materials available

Window Material: Glass (acrylic and safety glass options available)

Pointer: Black-painted aluminum, non-adjustable

Dial: White with black markings

Movement: 300 SS

Ranges: 30# thru 600#, incl. vac/30 psi lowest. See PI page SA/PI-16 for standard ranges. Other ranges available on application

Type 1032 Fractional Sanitary Pressure Gauge

DIMENSIONS

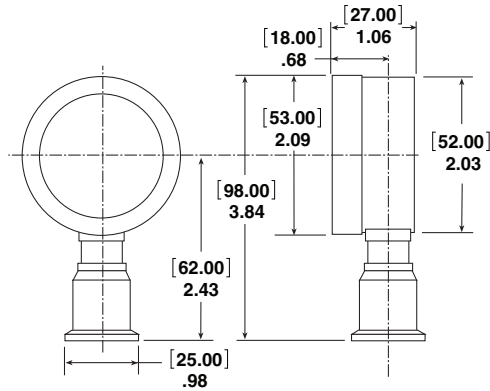

STANDARD PRESSURE RANGES

Pressure				
psi	Figure int.		Minor grad.	
0/30	5		0.5	
0/60	10		1	
0/100	10		1	
0/160	20		2	
0/200	40		5	
0/300	50		5	
0/400	100		10	
0/600	100		10	
Compound				
	Figure int.		Minor grad.	
	in. Hg	psi	in. Hg	psi
30" Hg/30 psi	10	5	1	0.5
30" Hg/60 psi	10	10	2	1
30" Hg/100 psi	10	10	5	2

Order Coding Example

20	1032	S	15	L	XSG	100#
----	------	---	----	---	-----	------

SIZE	TYPE	SYSTEM (TUBE & SOCKET)	PROCESS CONNECTION SIZE	CONNECTION LOCATION	OPTIONS (X VARIATIONS)	RANGE (psi)
(20) 2-inch	1032	(S) 316 SS Bourdon Tube and Socket	(75) 3/4 NPT male	(L) Lower	(C4) Individual calibration chart (NH) St. St. Tag (NN) Paper tag bonded (PD) Acrylic window (SG) Safety glass window (ZY) ⁽¹⁾ Flutterguard lubricated movement application	0-30 0-100 0-160 0-200 0-300 0-400 0-600 30"Hg/30# 30"Hg/60# 30"Hg/100#
*See PI page SA/PI-16 for standard ranges. Other ranges available on application.						

(1) XZY Flutterguard design is not recommended for gauges expected to be exposed to temperatures over 200°F (93°C). This includes gauges subjected to autoclaving.